

ICSE

**Year 2019
Examination**

Analysis of Pupil Performance

MATHEMATICS



Pioneering Excellence in Education since 1958

**Research Development and Consultancy Division
Council for the Indian School Certificate Examinations
New Delhi**

Year 2019

Published by:

Research Development and Consultancy Division (RDCD)

Council for the Indian School Certificate Examinations

Pragati House, 3rd Floor

47-48, Nehru Place

New Delhi-110019

Tel: (011) 26413820/26411706

E-mail: council@cisce.org

© Copyright, Council for the Indian School Certificate Examinations

All rights reserved. The copyright to this publication and any part thereof solely vests in the Council for the Indian School Certificate Examinations. This publication and no part thereof may be reproduced, transmitted, distributed or stored in any manner whatsoever, without the prior written approval of the Council for the Indian School Certificate Examinations.

FOREWORD

This document of the Analysis of Pupils' Performance at the ISC Year 12 and ICSE Year 10 Examination is one of its kind. It has grown and evolved over the years to provide feedback to schools in terms of the strengths and weaknesses of the candidates in handling the examinations.

We commend the work of Mrs. Shilpi Gupta (Deputy Head) of the Research Development and Consultancy Division (RDCD) of the Council and her team, who have painstakingly prepared this analysis. We are grateful to the examiners who have contributed through their comments on the performance of the candidates under examination as well as for their suggestions to teachers and students for the effective transaction of the syllabus.

We hope the schools will find this document useful. We invite comments from schools on its utility and quality.

October 2019

**Gerry Arathoon
Chief Executive & Secretary**

The Council has been involved in the preparation of the ICSE and ISC Analysis of Pupil Performance documents since the year 1994. Over these years, these documents have facilitated the teaching-learning process by providing subject/ paper wise feedback to teachers regarding performance of students at the ICSE and ISC Examinations. With the aim of ensuring wider accessibility to all stakeholders, from the year 2014, the ICSE and the ISC documents have been made available on the Council's website www.cisce.org.

The documents include a detailed qualitative analysis of the performance of students in different subjects which comprises of examiners' comments on common errors made by candidates, topics found difficult or confusing, marking scheme for each question and suggestions for teachers/ candidates.

In addition to a detailed qualitative analysis, the Analysis of Pupil Performance documents for the Examination Year 2019 also have a component of a detailed quantitative analysis. For each subject dealt with in the document, both at the ICSE and the ISC levels, a detailed statistical analysis has been done, which has been presented in a simple user-friendly manner.

It is hoped that this document will not only enable teachers to understand how their students have performed with respect to other students who appeared for the ICSE/ISC Year 2019 Examinations, but also provide information on how they have performed within the Region or State, their performance as compared to other Regions or States, etc. It will also help develop a better understanding of the assessment/ evaluation process. This will help teachers in guiding their students more effectively and comprehensively so that students prepare for the ICSE/ ISC Examinations, with a better understanding of what is required from them.

The Analysis of Pupil Performance document for ICSE for the Examination Year 2019 covers the following subjects: English (English Language, Literature in English), Hindi, History, Civics and Geography (History and Civics, Geography), Mathematics, Science (Physics, Chemistry, Biology), Commercial Studies, Economics, Computer Applications, Economic Applications, Commercial Applications.

Subjects covered in the ISC Analysis of Pupil Performance document for the Year 2019 include English (English Language and Literature in English), Hindi, Elective English, Physics (Theory), Chemistry (Theory), Biology (Theory), Mathematics, Computer Science, History, Political Science, Geography, Sociology, Psychology, Economics, Commerce, Accounts and Business Studies.

I would like to acknowledge the contribution of all the ICSE and the ISC examiners who have been an integral part of this exercise, whose valuable inputs have helped put this document together.

I would also like to thank the RDCD team of Dr. M.K. Gandhi, Dr. Manika Sharma, Mrs. Roshni George and Mrs. Mansi Guleria who have done a commendable job in preparing this document.

October 2019

Shilpi Gupta
Deputy Head - RDCD

CONTENTS

	Page No.
<i>FOREWORD</i>	<i>i</i>
<i>PREFACE</i>	<i>ii</i>
INTRODUCTION	1
QUANTITATIVE ANALYSIS	3
QUALITATIVE ANALYSIS	10

INTRODUCTION

This document aims to provide a comprehensive picture of the performance of candidates in the subject. It comprises of two sections, which provide Quantitative and Qualitative analysis results in terms of performance of candidates in the subject for the ICSE Year 2019 Examination. The details of the Quantitative and the Qualitative analysis are given below.

Quantitative Analysis

This section provides a detailed statistical analysis of the following:

- Overall Performance of candidates in the subject (Statistics at a Glance)
- State wise Performance of Candidates
- Gender wise comparison of Overall Performance
- Region wise comparison of Performance
- Comparison of Region wise performance on the basis of Gender
- Comparison of performance in different Mark Ranges and comparison on the basis of Gender for the top and bottom ranges
- Comparison of performance in different Grade categories and comparison on the basis of Gender for the top and bottom grades

The data has been presented in the form of means, frequencies and bar graphs.

Understanding the tables

Each of the comparison tables shows N (Number of candidates), Mean Marks obtained, Standard Errors and t-values with the level of significance. For t-test, mean values compared with their standard errors indicate whether an observed difference is likely to be a true difference or whether it has occurred by chance. The t-test has been applied using a confidence level of 95%, which means that if a difference is marked as 'statistically significant' (with * mark, refer to t-value column of the table), the probability of the difference occurring by chance is less than 5%. In other words, we are 95% confident that the difference between the two values is true.

t-test has been used to observe significant differences in the performance of boys and girls, gender wise differences within regions (North, East, South and West), gender wise differences within marks ranges (Top and bottom ranges) and gender wise differences within grades awarded (Grade 1 and Grade 9) at the ICSE Year 2019 Examination.

The analysed data has been depicted in a simple and user-friendly manner.

Given below is an example showing the comparison tables used in this section and the manner in which they should be interpreted.

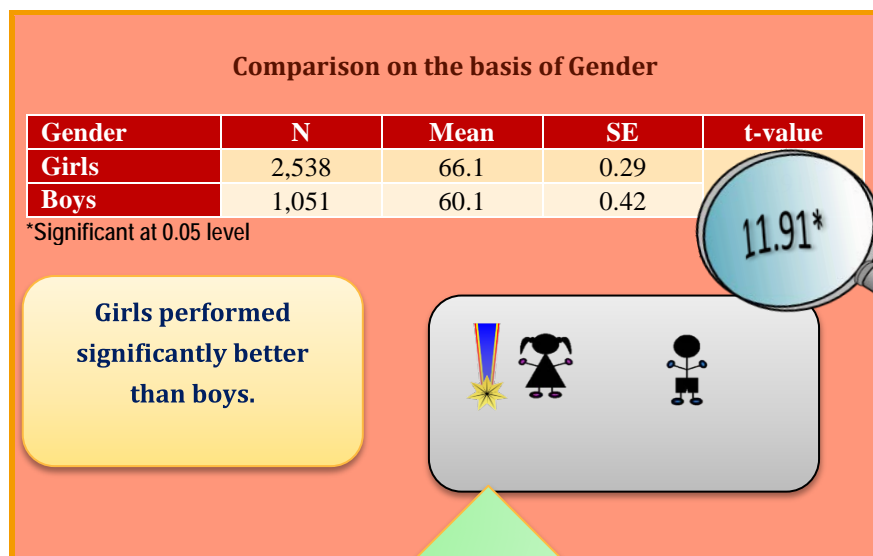

The table shows comparison between the performances of boys and girls in a particular subject. The t-value of 11.91 is significant at 0.05 level (mentioned below the table) with a mean of girls as 66.1 and that of boys as 60.1. It means that there is significant difference between the performance of boys and girls in the subject. The probability of this difference occurring by chance is less than 5%. The mean value of girls is higher than that of boys. It can be interpreted that girls are performing significantly better than boys.

The results have also been depicted pictographically. In this case, the girls performed significantly better than the boys. This is depicted by the girl with a medal.

Qualitative Analysis

The purpose of the qualitative analysis is to provide insights into how candidates have performed in individual questions set in the question paper. This section is based on inputs provided by examiners from examination centres across the country. It comprises of question wise feedback on the performance of candidates in the form of *Comments of Examiners* on the common errors made by candidates along with *Suggestions for Teachers* to rectify/ reduce these errors. The *Marking Scheme* for each question has also been provided to help teachers understand the criteria used for marking. Topics in the question paper that were generally found to be difficult or confusing by candidates, have also been listed down, along with general suggestions for candidates on how to prepare for the examination/ perform better in the examination.

QUANTITATIVE ANALYSIS

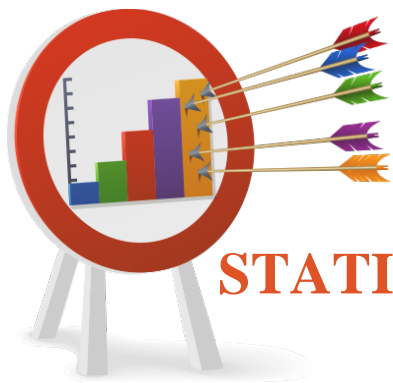

STATISTICS AT A GLANCE

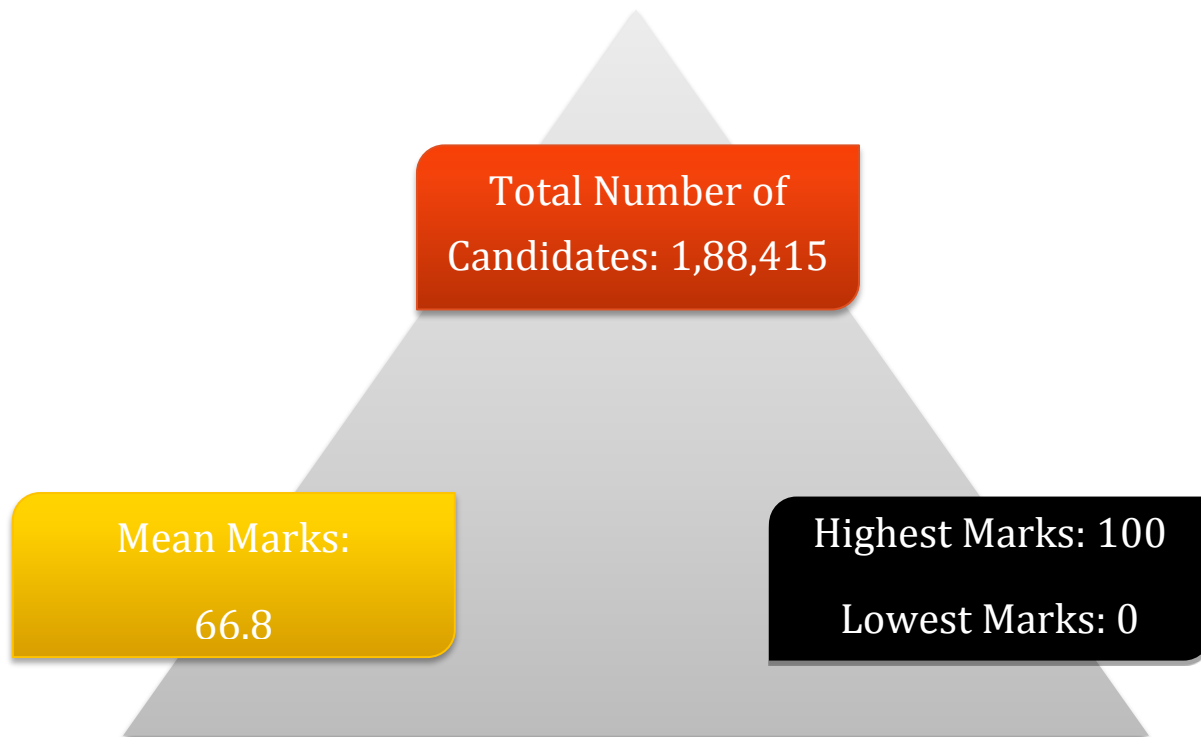



PERFORMANCE (STATE-WISE & FOREIGN)

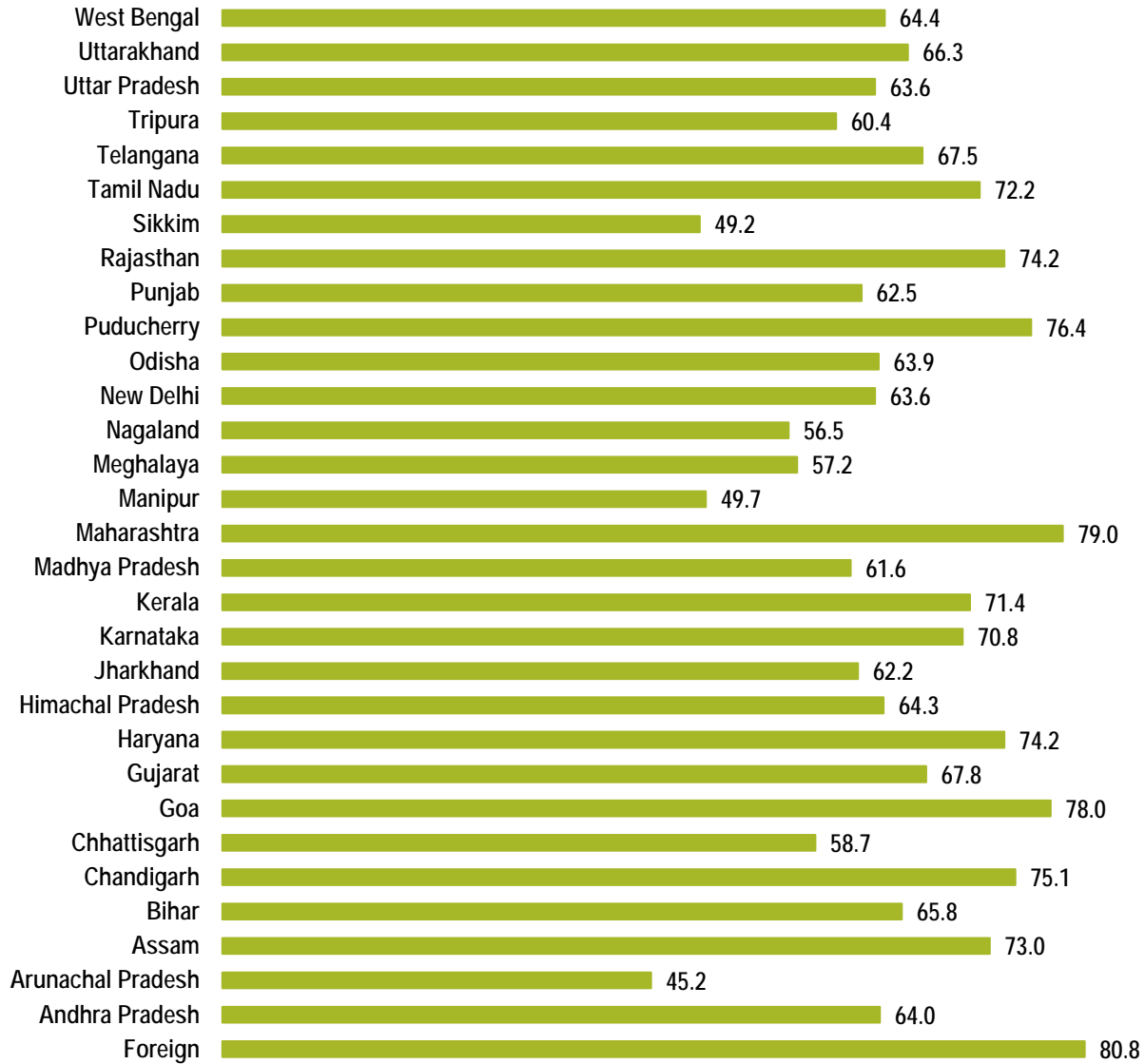

The States/UTs of Maharashtra, Goa and Puducherry secured highest mean marks. Mean marks secured by candidates studying in schools abroad were 80.8.



GENDER-WISE COMPARISON



GIRLS

Mean Marks: 67.6

Number of
Candidates: 85,443



BOYS

Mean Marks: 66.2

Number of
Candidates: 1,02,972

Comparison on the basis of Gender

Gender	N	Mean	SE	t-value
Girls	85,443	67.6	0.07	14.07*
Boys	1,02,972	66.2	0.07	

*Significant at 0.05 level

**Girls performed
significantly better than
boys.**





REGION-WISE COMPARISON

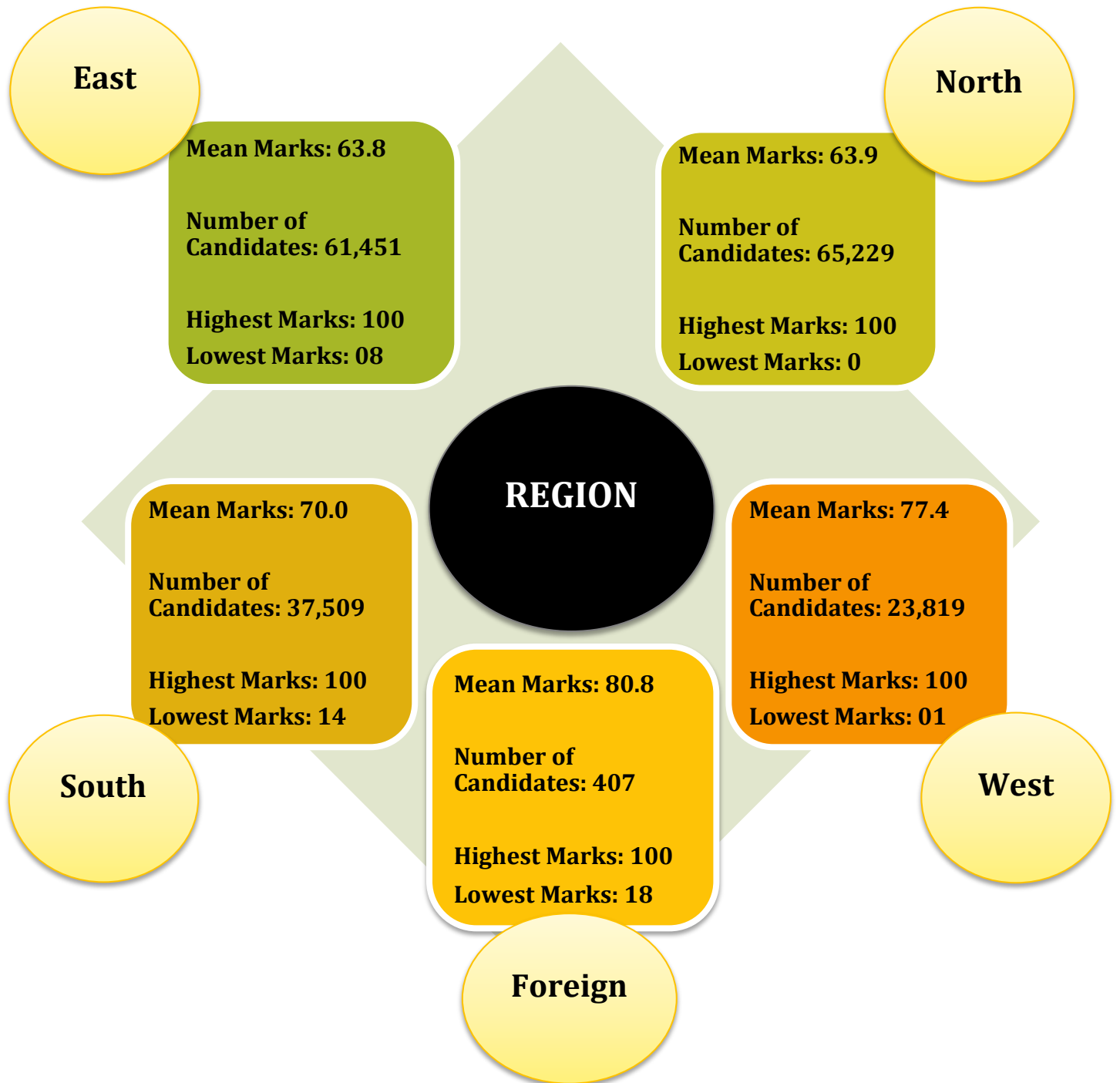

Mean Marks obtained by Boys and Girls-Region wise

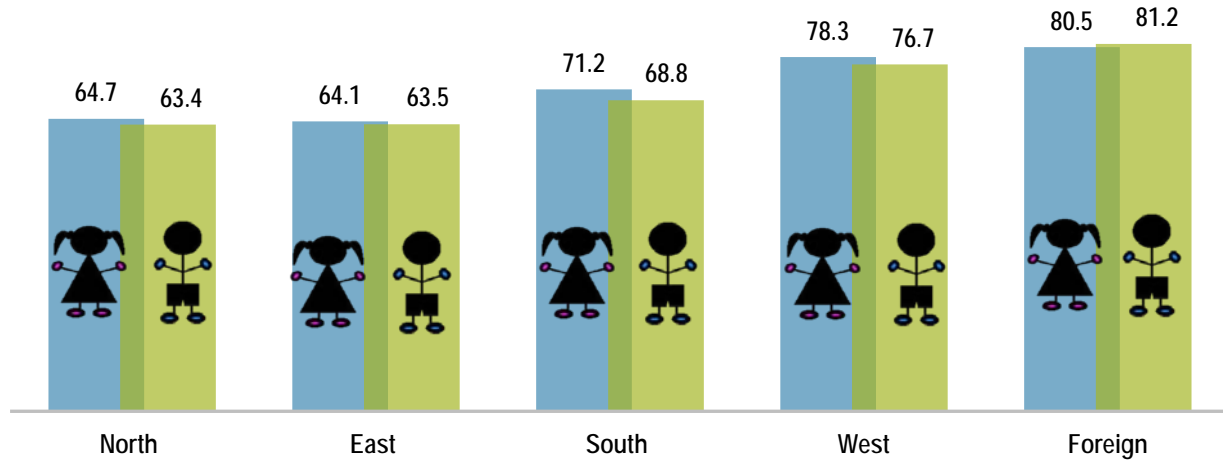

Comparison on the basis of Gender within Region

Region	Gender	N	Mean	SE	t-value
North (N)	Girls	28,412	64.7	0.13	7.51*
	Boys	36,817	63.4	0.12	
East (E)	Girls	27,698	64.1	0.14	2.93*
	Boys	33,753	63.5	0.13	
South (S)	Girls	18,628	71.2	0.14	11.54*
	Boys	18,881	68.8	0.15	
West (W)	Girls	10,491	78.3	0.18	6.62*
	Boys	13,328	76.7	0.17	
Foreign (F)	Girls	214	80.5	1.28	-0.36
	Boys	193	81.2	1.35	

*Significant at 0.05 level

The performance of girls was significantly better than that of boys in all the regions except foreign region.

REGION (N, E, S, W)

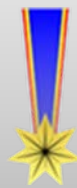



MARK RANGES : COMPARISON GENDER-WISE

Comparison on the basis of gender in top and bottom mark ranges

Marks Range	Gender	N	Mean	SE	t-value
Top Range (81-100)	Girls	31,025	90.2	0.03	-2.90*
	Boys	36,111	90.3	0.03	
Bottom Range (0-20)	Girls	936	18.8	0.05	1.75
	Boys	1797	18.6	0.04	

*Significant at 0.05 level

Marks Range (81-100)

Performance of boys was significantly better than the performance of girls.

Marks Range (81-100)

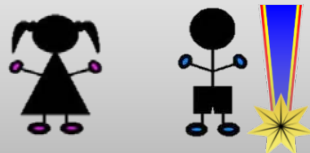

Marks Range (0-20)

No significant difference was observed between the average performance of girls and boys.

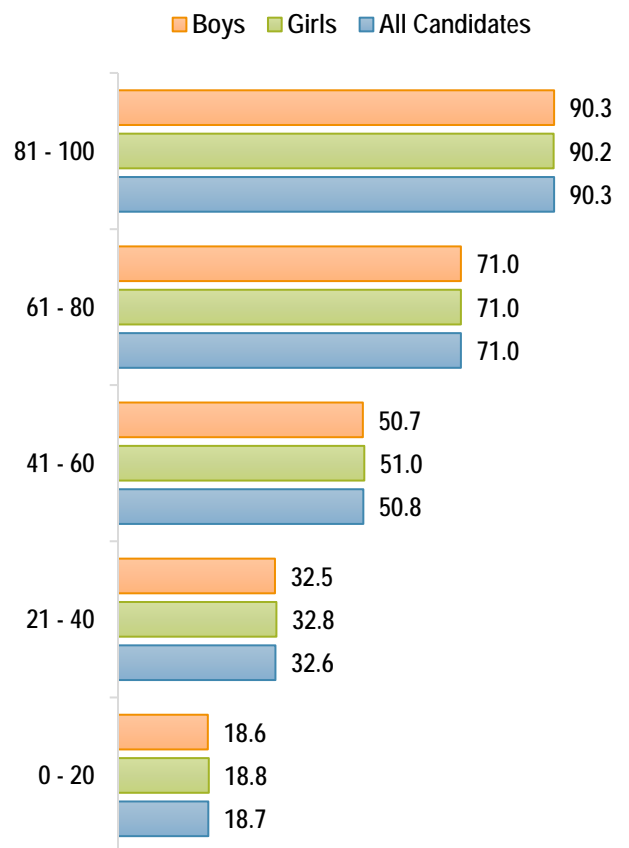



GRADES AWARDED : COMPARISON GENDER-WISE

Comparison on the basis of gender in Grade 1 and Grade 9

Grades	Gender	N	Mean	SE	t-value
Grade 1	Girls	16,808	94.4	0.02	-0.57
	Boys	19,977	94.5	0.02	
Grade 9	Girls	936	18.8	0.05	1.75
	Boys	1797	18.6	0.04	

No significant difference was observed between the average performance of girls and boys.

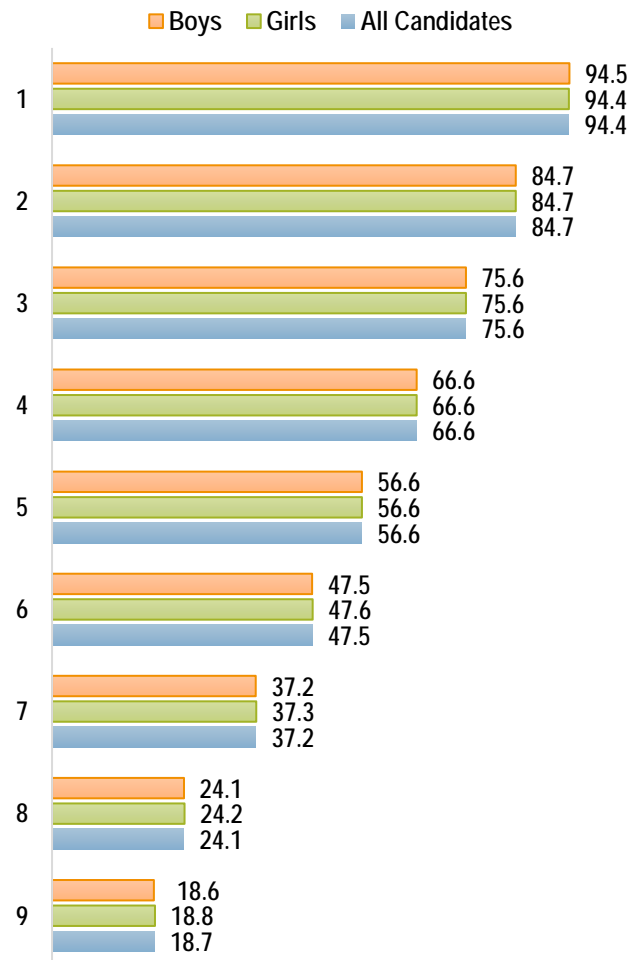

QUALITATIVE ANALYSIS

SECTION A (40 Marks)

Attempt all questions from this Section.

Question 1

- (a) Solve the following inequation and write down the solution set: [3]

$$11x - 4 < 15x + 4 \leq 13x + 14, x \in W$$

Represent the solution on a real number line.

- (b) A man invests ₹4500 in shares of a company which is paying 7.5% dividend. [3]

If ₹100 shares are available at a discount of 10%.

Find:

- (i) Number of shares he purchases.
- (ii) His annual income.
- (c) In a class of 40 students, marks obtained by the students in a class test (out of 10) are [4]
given below:

Marks	1	2	3	4	5	6	7	8	9	10
Number of students	1	2	3	3	6	10	5	4	3	3

Calculate the following for the given distribution:

- (i) Median
- (ii) Mode

Comments of Examiners

- (a) Many candidates made errors in transposing like terms on same side e.g., $15x - 11x < -4 - 4$. Some candidates made mistakes in solving the inequation. Most of the errors were pertaining to positive and negative signs like, $-4x < 8 \Rightarrow x < -2$.
A number of candidates did not write down the solution set after solving the given inequation. Some did not use set notation method with curly brackets, and some represented as real number solution stating $x \in \mathbb{R}$. Several candidates represented solution incorrectly on the number line i.e., $X \in \mathbb{N}$ was considered as $x \in \mathbb{R}$. A few candidates failed to put extra number on each side of solution for indicating the continuity of the number line.
- (b) (i) Common errors made by many candidates were in finding annual income, in considering Market Value (MV) i.e., instead of taking discounted MV as ₹90 it was taken as either ₹100 or ₹110. Thus, made mistake in finding the number of shares purchased.
- (ii) Annual income was also calculated incorrectly due to error in finding the number of shares.
- (c) (i) A large number of the candidates were unable to understand that the given data is a non-grouped frequency distribution. To identify the median, instead of finding the cumulative frequency, they tried to find it directly. Some tried to find the median by plotting the points directly on a graph paper. Some candidates tried to find the median by writing all 40 numbers.
- (ii) Several candidates could not identify mode correctly.

Suggestions for teachers

- Revise the concepts of number system viz., Natural numbers (N), Whole numbers (W), Integers (Z), Real numbers (R) frequently.
- Give adequate practice for transpositions of variables and constants and division by negative number in inequations.
- Teach the method of writing the solution set in set notation form.
- Clarify the rules of representation of the solution on the number line whether it belongs to N, W, Z or R.
- Build the concept of Nominal Value (NV), Market Value (MV), dividend etc by giving examples.
- Discuss the Simple distribution, Non-grouped frequency distribution and Grouped frequency distribution in detail with corresponding method of measure of their central tendencies.
- Drill students with basic concepts like inequations, shares & dividends, median, mode and related application-based problems.

MARKING SCHEME

Question 1

(a)	$11x - 4 < 15x + 4 \leq 13x + 14, x \in \mathbb{W}$		
	$11x - 4 < 15x + 4$	$15x + 4 \leq 13x + 14$	(Transforming x terms on one side and constants on the other side)
	$11x - 15x < 4 + 4$	$15x - 13x \leq 14 - 4$	
	$-4x < 8$	$2x \leq 10$	
	$+4x > -8$	$x \leq 5$	
	$x > -2$		

Solution: {0, 1, 2, 3, 4, 5}

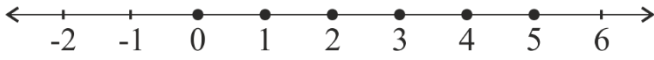

(b) (i) Market value of each share = ₹100 – 10% of ₹100 = ₹90

$$\therefore \text{Number of shares} = \frac{4500}{90} = 50$$

(ii) Annual Income = $\frac{7.5 \times 100 \times 50}{100} = ₹375$

(c)

Marks (x)	No. of Students (f)	cf
1	1	1
2	2	3
3	3	6
4	3	9
5	6	15
6	10	25
7	5	30
8	4	34
9	3	37
10	3	40
	$\Sigma = 40$	

(i) Median = 6

(ii) Mode = 6

Question 2

(a) Using the factor theorem, show that $(x - 2)$ is a factor of $x^3 + x^2 - 4x - 4$. [3]

Hence factorise the polynomial completely.

(b) Prove that: [3]

$$(\operatorname{cosec} \theta - \sin \theta)(\sec \theta - \cos \theta)(\tan \theta + \cot \theta) = 1$$

- (c) In an Arithmetic Progression (A.P.) the fourth and sixth terms are 8 and 14 respectively. [4]

Find the:

- (i) first term
- (ii) common difference
- (iii) sum of the first 20 terms.

Comments of Examiners

- (a) A large number of candidates did not use Remainder-Factor Theorem to show that $(x - 2)$ is a factor of the given polynomial. Few of them did not conclude the remainder to be equal to 0. In some scripts, errors were observed in division of the polynomial by $(x - 2)$. Many candidates expressed the final answer by separating the factors by comma instead of expressing them in the product form as $(x - 2)(x + 1)(x + 2)$.
- (b) Many candidates made mistakes in substituting the reciprocal relations for the trigonometric ratios given in the question for example, $\operatorname{cosec} \theta$ is taken as $1/\cos \theta$ instead of $1/\sin \theta$ etc. while some candidates made mistakes in simplification of the expressions on the Left-Hand Side of the question. Some candidates made mistakes in using the identities like $\sin^2 \theta + \cos^2 \theta = 1$ correctly. Some expanded the whole expression and made mistakes in simplification and using standard identities.
- (c) Some candidates did not know the basic concepts of Arithmetic Progression (A.P.). Many candidates tried to solve the sum by trial & error method and got the six terms, but the necessary working was incorrect. Few candidates without framing equations like $a + 3d = 8$ and $a + 5d = 14$, wrote $d = 3$. Some candidates either used incorrect formulae or made errors in calculation. Therefore, they failed to get the value of the first term, common difference and sum of the first 20 terms correctly.

Suggestions for teachers

- Clarify the factor theorem / Remainder theorem thoroughly with examples.
- Advise students to write the factors in product form.
- Drilling of simple trigonometric identities to apply them appropriately in solving other identities.
- Insist upon showing working clearly.
- Teach the concept of the two series: Arithmetic Progression (AP) and Geometric Progression (GP) and their differences with different examples.
- Revise formulae for finding a term, common difference and summation of certain number of terms in Arithmetic Progression frequently.

MARKING SCHEME

Question 2

(a) $f(x) = x^3 + x^2 - 4x - 4$
 $f(2) = 2^3 + 2^2 - 4 \times 2 - 4$
 $= 8 + 4 - 8 - 4$
 $= 0$
 $\therefore x - 2$ is a factor of $f(x)$
 $x - 2 \mid x^3 + x^2 - 4x - 4 \mid x^2 + 3x + 2$

$$\begin{array}{r} x^3 - 2x^2 \\ \hline 3x^2 - 4x \\ 3x^2 - 6x \\ \hline 2x - 4 \\ 2x - 4 \\ \hline x \end{array}$$

$x^2 + 3x + 2 = (x + 1)(x + 2)$
 $\therefore x^3 + x^2 - 4x - 4 = (x - 2)(x + 1)(x + 2)$

(b) $(\operatorname{cosec} \theta - \sin \theta)(\sec \theta - \cos \theta)(\tan \theta + \cot \theta) = 1$

$$\begin{aligned} LHS &= \left(\frac{1}{\sin \theta} - \sin \theta \right) \left(\frac{1}{\cos \theta} - \cos \theta \right) \left(\frac{\sin \theta}{\cos \theta} + \frac{\cos \theta}{\sin \theta} \right) \\ &= \left(\frac{1 - \sin^2 \theta}{\sin \theta} \right) \times \left(\frac{1 - \cos^2 \theta}{\cos \theta} \right) \left(\frac{\sin^2 \theta + \cos^2 \theta}{\sin \theta \cos \theta} \right) \\ &= \frac{\cos^2 \theta}{\sin \theta} \times \frac{\sin^2 \theta}{\cos \theta} \times \frac{1}{\sin \theta \cos \theta} \\ &= 1 = RHS \end{aligned}$$

(c) Let a be the first term and d the common difference

$$\therefore a + 3d = 8 \text{ and } a + 5d = 14$$

(i) Solving $a = -1$

(ii) $d = 3$

(iii) $S_n = \frac{n}{2} \{2 \times a + (n - 1) d\}$

$$S_{20} = \frac{20}{2} \{2 \times (-1) + (20 - 1) 3\}$$

$$S_{20} = 10(-2 + 57)$$

$$S_{20} = 550$$

Question 3

(a) Simplify

[3]

$$\sin A \begin{bmatrix} \sin A & -\cos A \\ \cos A & \sin A \end{bmatrix} + \cos A \begin{bmatrix} \cos A & \sin A \\ -\sin A & \cos A \end{bmatrix}$$

(b) M and N are two points on the X axis and Y axis respectively.

[3]

P (3, 2) divides the line segment MN in the ratio 2: 3.

Find:

(i) the coordinates of M and N

(ii) slope of the line MN.

(c) A solid metallic sphere of radius 6 cm is melted and made into a solid cylinder of height 32 cm. Find the:

[4]

(i) radius of the cylinder

(ii) curved surface area of the cylinder

Take $\pi = 3.1$

Comments of Examiners

- (a) Some candidates made mistakes in scalar multiplication of the matrix. For Example,

$$\sin A \begin{bmatrix} \sin A & -\cos A \\ \cos A & \sin A \end{bmatrix} = \begin{bmatrix} \sin^2 A & \sin A - \cos A \\ \sin A \cos A & \sin^2 A \end{bmatrix}$$

Some made errors in matrix addition and did not apply the identity $\sin^2 A + \cos^2 A = 1$ for simplifying the final matrix. A number of candidates put some specific value, e.g., $90^\circ, 60^\circ$ etc and tried to solve the problem.

- (b)(i) Several candidates made errors in identifying coordinates of points on x-axis and y-axis, e.g., (x,0) and (0,y) was taken as (0,x), (y,0) or as (x_1, y_1) and (x_2, y_2) .

Many candidates instead of using the given ratio $MP:PN = 2:3$ took $NP:MP = 2:3$.

Some candidates used midpoint formula to find coordinates of P. A number of candidates made calculation errors. Some overlooked the last part of the question and did not find slope of the line MN.

- (ii) As some candidates obtained incorrect coordinates of M and N, they made error in finding the slope of the line MN. Some candidates were not conversant with the formula to find the slope of a line.

- (c) (i) Some candidates used incorrect formula for finding the volume of a sphere and a cylinder, e.g., volume of sphere was taken as $\frac{4}{3}\pi r^2$ or $\frac{2}{3}\pi r^3$ and volume of cylinder was taken as $2\pi r^2 h$ or $\pi \times 6^2 \times 32$ instead of $\pi r^2 h$. Some candidates did not use the value of π given in the question paper, hence, got incorrect answer.

- (ii) Many candidates used incorrect formula for finding curved surface area of the cylinder, e.g., used $2\pi r^2 h$ instead of $2\pi rh$.

Suggestions for teachers

- Give thorough practice of basic operations like addition, multiplication of matrices and solving matrix equation.
- Instruct students to show each step of working and also to use matrix notation for each step.
- Advise students to read the question carefully and take note of every part to be attempted.
- Familiarise students with the logic of assigning coordinates to the points taken on the x-axis and on the y-axis.
- Teach students that if a point divides a line segment in the ratio m:n ($m \neq n$) then m: n is not equal to n: m.
- Give adequate practice to the students for application of various mensuration formulae of volume and surface area of solids.
- Give revision of volume and surface area related application-based problems to the students to clarify their concepts.
- Train students to handle carefully the operation of multiplication and division with decimal numbers.

MARKING SCHEME

Question 3

$$\begin{aligned} \text{(a)} \quad & \sin A \begin{bmatrix} \sin A & -\cos A \\ \cos A & \sin A \end{bmatrix} + \cos A \begin{bmatrix} \cos A & \sin A \\ -\sin A & \cos A \end{bmatrix} \\ & = \begin{bmatrix} \sin^2 A & -\sin A \cos A \\ \sin A \cos A & \sin^2 A \end{bmatrix} + \begin{bmatrix} \cos^2 A & \cos A \sin A \\ -\sin A \cos A & \cos^2 A \end{bmatrix} \\ & = \begin{bmatrix} \sin^2 A + \cos^2 A & -\sin A \cos A + \cos A \sin A \\ \sin A \cos A - \sin A \cos A & \sin^2 A + \cos^2 A \end{bmatrix} \\ & \qquad \qquad \qquad = \begin{bmatrix} 1 & 0 \\ 0 & 1 \end{bmatrix} \end{aligned}$$

(b)	<p>Let M(x, 0) and N(0,0) and N(0, y) be the two points on the X and Y axis respectively.</p> <p>(i) P(3, 2) divides MN in the ratio 2 : 3</p> $\therefore 3 = \frac{2 \times 0 + 3 \times x}{2 + 3} \quad \therefore x = 5$ $2 = \frac{2 \times y + 3 \times 0}{2 + 3} \quad \therefore y = 5$ <p>M (5, 0), N(0, 5)</p> <p>(ii) Slope of MN: $\frac{5-0}{0-5} = -1$</p>
(c)	<p>Let the radius of the cylinder be 'r'</p> <p>Volume of sphere = $\frac{4}{3}\pi r^3 = \frac{4}{3} \times \pi \times 6^3$</p> <p>Volume of cylinder = $\pi r^2 h = \pi \times r^2 \times 32$</p> <p>(i) $\therefore \frac{4}{3}\pi \times 6^3 = \pi \times r^2 \times 32$</p> $\therefore r^2 = \frac{4 \times 6^3}{3 \times 32} = 3^2$ $\therefore r = 3 \text{ cm}$ <p>(ii) Curved surface area of cylinder = $2\pi r h$</p> $= 2 \times 3.1 \times 3 \times 32$ $= 595.2 \text{ cm}^2$

Question 4

- (a) The following numbers, $K + 3$, $K + 2$, $3K - 7$ and $2K - 3$ are in proportion. Find K. [3]
- (b) Solve for x the quadratic equation $x^2 - 4x - 8 = 0$. [3]
Give your answer correct to three significant figures.
- (c) Use ruler and compass only for answering this question. [4]
Draw a circle of radius 4 cm. Mark the centre as O. Mark a point P outside the circle at a distance of 7 cm from the centre. Construct two tangents to the circle from the external point P.
Measure and write down the length of any one tangent.

Comments of Examiners

- (a) Some candidates did not use the property of proportion correctly. Many candidates used arithmetic progression to solve the sum instead of ratio and proportion. A number of candidates used componendo and dividendo but their working was incorrect. Several candidates did not equate the expression $k^2 - 4k - 5$ to zero. A few candidates neglected the final answer 5 and -1.
- (b) Many candidates used incorrect formula for finding roots of the quadratic equation. Some used correct formula but incorrect substitution, e.g., $c = 8$ instead of -8 . Many candidates could not express $\sqrt{48}$ as $4\sqrt{3}$ and a few failed to substitute $\sqrt{3}=1.732$. Some candidates used long division method to find $\sqrt{48}$ and went wrong in calculation. Several candidates did not express the final answer up to three significant figures as it was asked in the question.
- (c) Several candidates did not take distance $OP = 7\text{cm}$ as it was given in the question. Many candidates marked midpoint of OP using ruler instead of constructing the perpendicular bisector. Some candidates followed some other incorrect methods for construction. A number of candidates measured the length of the tangent incorrectly. Some candidates wasted time in writing the steps of construction which was not asked in the question.

Suggestions for teachers

- Advise students to read the question carefully and apply the condition correctly as given in the problem.
- Train students to analyse a given question with what is given and what is to be evaluated.
- Acquaint students with the use of mathematical tables to get the value of $\sqrt{48}$ directly instead of wasting time to get the value using division method which is not necessary.
- Clarify significant figures thoroughly with relevant examples.
- Insist upon giving all traces of construction.
- Instruct students to read the construction-based question carefully and solve the problem as per its requirement.

MARKING SCHEME

Question 4

- (a) $K + 3, K + 2, 3K - 7$ and $2K - 3$ are in proportion

$$\therefore \frac{K + 3}{K + 2} = \frac{3K - 7}{2K - 3}$$

$$\text{Or } (K + 3)(2K - 3) = (3K - 7)(K + 2)$$

$$2K^2 + 6K - 3K - 9 = 3K^2 - 7K + 6K - 14$$

$$K^2 - 4K - 5 = 0$$

$$(K - 5)(K + 1) = 0$$

$$\therefore K = 5, -1$$

- (b) $x^2 - 4x - 8 = 0$

$$x = \frac{-(-4) \pm \sqrt{(-4)^2 - 4.1.(-8)}}{2 \times 1}$$

$$= \frac{4 \pm \sqrt{16 + 32}}{2}$$

$$= \frac{4 \pm \sqrt{48}}{2}$$

$$= \frac{4 \pm 4\sqrt{3}}{2}$$

$$= 2 \pm 2\sqrt{3} = 2 \pm 2 \times 1.732$$

$$x = 2 \pm 3.464$$

$$\therefore x = 5.464 \text{ or } -1.464$$

$$x = 5.46, -1.46 \quad (\text{Correct to three significant figures.})$$

- (c) Circle and point P
Bisecting OP and drawing circle
Two tangents

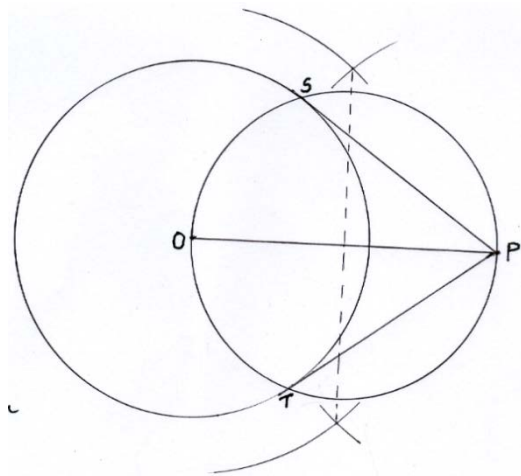

$$PS = PT = (5.7 \pm 0.2) \text{ cm}$$

SECTION B (40 Marks)

Attempt any four questions from this Section

Question 5

- (a) There are 25 discs numbered 1 to 25. They are put in a closed box and shaken [3]
thoroughly. A disc is drawn at random from the box.

Find the probability that the number on the disc is:

- (i) an odd number
- (ii) divisible by 2 and 3 both.
- (iii) a number less than 16.
- (b) Rekha opened a recurring deposit account for 20 months. The rate of interest is 9% per [3]
annum and Rekha receives ₹441 as interest at the time of maturity.

Find the amount Rekha deposited each month.

- (c) Use a graph sheet for this question. [4]

Take 1 cm = 1 unit along both x and y axis.

- (i) Plot the following points:

A(0,5), B(3,0), C(1,0) and D(1,-5)

- (ii) Reflect the points B, C and D on the y axis and name them as B', C' and D'
respectively.

- (iii) Write down the coordinates of B', C' and D'.

- (iv) Join the points A, B, C, D, D', C', B', A in order and give a name to the closed figure
ABCDD'C'B'.

Comments of Examiners

(a) (i) Common errors noticed in sub parts (i) ,(ii) and (iii) of this question were:

- total outcome or favourable outcome was incorrect in all parts.
- favourable outcome of odd numbers was taken as 13.
- numbers divisible by 2 and 3 both were listed incorrectly. Many candidates misread the condition as 2 or 3. Hence, favorable outcomes was 16 instead of 4.
- the probability was not expressed in the simplest form, e.g., $\frac{15}{25}$ was not written as $\frac{3}{5}$.

(b) Some candidates considered ₹441 as maturity value and some considered it as monthly installment instead of taking it as interest.

Many candidates either used incorrect formula or made errors in calculation.

(c) Following anomalies were observed in the solution of graph-based question:

- incorrect choice of scale i.e., 2cm = 1unit instead of 1cm = 1unit as it was given in the question paper.
- marked axes incorrectly.
- plotted A (0,5), B (3,0) and C(1,0) incorrectly.
- plotted the points correctly but did not label them.
- neither join the points nor completed the figure.
- reflected points B', C', and D' were marked incorrectly.
- coordinates of B', C', and D' were not written correctly.
- did not name the closed figure as given in the question.

Suggestions for teachers

- Instruct students to list the outcomes of both total and favourable events.
- Concept of AND, OR in finding the probability of a number on the disc divisible by 2 and 3 or 2 or 3 require more drilling.
- In probability, emphasise in giving answers in the simplest form.
- Instruct students to read the question carefully so as not to go wrong with given data.
- More drilling of calculation based sums minimise calculation errors.
- Formulae for finding the monthly installment, MV or number of months need repeated drilling.
- Candidates must be instructed to read each part carefully for a question on reflection.
- More practice required on problems leading to Graphs with proper choice of axis.
- Give adequate practice to the students to identify points on the x and y axis in the class.

MARKING SCHEME

Question 5

- (a) Total number of outcomes = 25
- (i) favourable outcomes are {1, 3, 5, 7, 11, 13, 15, 17, 19, 21, 23, 25}
∴ probability of being an odd number is $= \frac{12}{25}$
- (ii) favourable outcomes are {6, 12, 18, 24} i.e. 4
∴ probability of being divisible by both 2 and 3 is $= \frac{4}{25}$
- (iii) favourable outcomes are {1, 2, 3, 4, 5...15}, i.e. 15
∴ probability $= \frac{15}{25} = \frac{3}{5}$

(b) Let monthly deposit be ` x

$$\text{Interest} = \frac{P \times n(n+1) \times r}{100 \times 2 \times 12}$$

$$441 = \frac{x \times 20(20 + 1) \times 9}{100 \times 2 \times 12}$$

$$\frac{63x}{40} = 441 \quad \text{Equating interest to 441}$$

$$\therefore x = ₹280$$

(c)

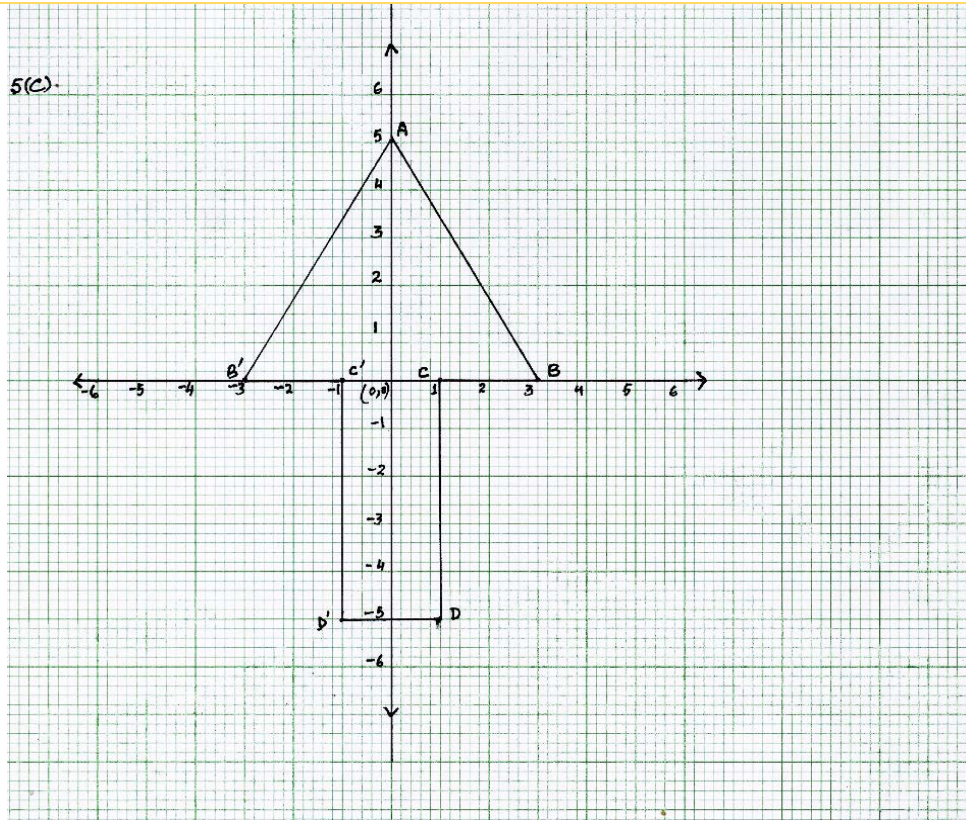

$$\text{(iii) } B(3, 0) \xrightarrow{y\text{-axis}} B'(-3, 0)$$

$$C(1, 0) \xrightarrow{y\text{-axis}} C'(-1, 0)$$

$$D(1, -5) \xrightarrow{y\text{-axis}} D'(-1, -5)$$

Plotting A, B, C, D

Reflected points B', C', D'

(iv) Arrow Head / Heptagon(or Septagon)

Question 6

(a) In the given figure, $\angle PQR = \angle PST = 90^\circ$, $PQ = 5$ cm and $PS = 2$ cm. [3]

(i) Prove that $\Delta PQR \sim \Delta PST$.

(ii) Find Area of ΔPQR : Area of quadrilateral SRQT.

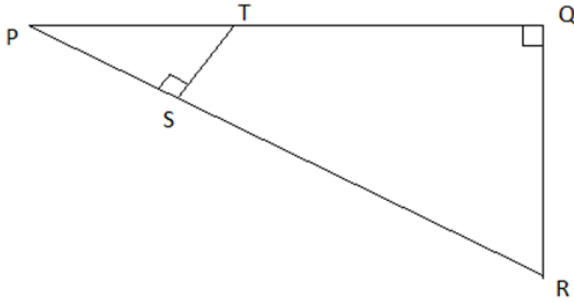

(b) The first and last term of a Geometrical Progression (G.P.) are 3 and 96 respectively. If the common ratio is 2, find: [3]

(i) ' n ' the number of terms of the G.P.

(ii) Sum of the n terms.

(c) A hemispherical and a conical hole is scooped out of a solid wooden cylinder. Find the volume of the remaining solid where the measurements are as follows: [4]

The height of the solid cylinder is 7 cm, radius of each of hemisphere, cone and cylinder is 3 cm. Height of cone is 3 cm.

Give your answer correct to the nearest whole number. Take $\pi = \frac{22}{7}$.

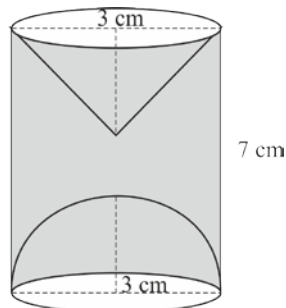

Comments of Examiners

- (a) (i) Many candidates could not identify the two sets of equal angles to prove $\Delta PQR \sim \Delta PST$
- (ii) Several candidates made mistake in writing $(\Delta PQR)/\Delta PST=25/4$. Hence, could not find area of ΔPQR : area of quadrilateral $\square SRQT$. Some candidates left the answer as 25/21 instead of writing 25:21 as mentioned in the Question.
- (b) (i) A number of candidates were unable to form the equations with given conditions. Due to conceptual errors related to Geometrical Progression many candidates were unable to find the value of n. Some tried to find n by trial and error method.
- (ii) Many candidates could not find the value of n but found the sum by using $S=(l-r-a)/(r-1)$ and got the correct answer. Some candidates used incorrect formula for finding the sum of n terms.
- (c) Some candidates made mistakes in applying the correct formula of one or more of solids (cylinder, hemisphere and cone) while a few made mistakes in substitution of values of radius and height of the solid/s scooped out of the cylinder. Some candidates took the value of $\pi = 3.14$ for calculation instead of the given value $22/7$. A few candidates made mistakes in rounding of the answer to the nearest whole number. Basic calculation errors were also noticed in many answers scripts.

Suggestions for teachers

- Build up the concept of similarity of triangles and related results by giving adequate practice and frequent class tests.
- Advise students to write down the proportional sides after proving similarity.
- Instruct students to read the question carefully and underline the points to be answered and the correct form of the answer.
- Advise students to understand the formulae related to sequence and series with reference to the context and use them to solve the problems by following the correct method and clearly showing all steps of working.
- Train students to calculate the volume of a remaining solid by putting all the volumes in a combine manner with plus and minus sign instead of calculating each volume separately.
- Give sufficient practice in problems based on volume and surface area of different solids.
- Read the question carefully and use the given value of π . Use $\pi = 22/7$ in such sums unless otherwise if it is mentioned.
- More drilling of such sums could rectify the calculation errors.

MARKING SCHEME

Question 6

(a)

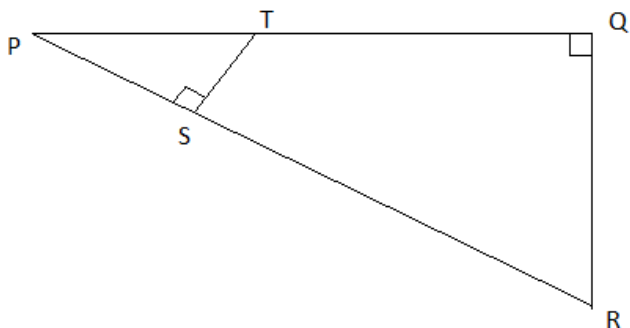

(i) In $\triangle PQR$ and $\triangle PST$

$$\angle PQR = \angle PST = 90^\circ \text{ (given)}$$

$\angle P$ is common to both triangles.

$$\therefore \triangle PQR \sim \triangle PST \quad \text{(AAA)}$$

(ii) $\therefore \triangle PQR : \triangle PST = 5^2 : 2^2$

$$\therefore \triangle PQR : \text{quadrilateral SRQT} = 25 : 21$$

(b)

1st term $a = 3$ and last term = 96, $r = 2$

$$\therefore T_n = 96 = a r^{n-1}$$

$$96 = 3 \times 2^{n-1}$$

$$32 = 2^{n-1}$$

$$2^5 = 2^{n-1}$$

$$\therefore n-1 = 5 \text{ hence } n = 6$$

$$S_6 = \frac{a(r^n - 1)}{r - 1}$$

$$= \frac{3(2^6 - 1)}{2 - 1} = 3(64 - 1) = 3 \times 63 = 189$$

(c)

Remaining volume = Volume of Cylinder – (volume of cone + volume of hemisphere)

$$= \pi r^2 h - \left(\frac{1}{3} \pi r^2 h + \frac{2}{3} \pi r^3 \right)$$

$$= \frac{22}{7} \times 3^2 \times 7 - \left(\frac{1}{3} \times \frac{22}{7} \times 3^2 \times 3 + \frac{2}{3} \times \frac{22}{7} \times 3^3 \right)$$

$$= \frac{22}{7} \times 3^2 [7 - (1 + 2)]$$

$$= \frac{22}{7} \times 3^2 \times 4 = \frac{792}{7} = 113.1 = 113 \text{ cm}^3$$

Question 7

- (a) In the given figure AC is a tangent to the circle with centre O. [3]
If $\angle ADB = 55^\circ$, find x and y . Give reasons for your answers.

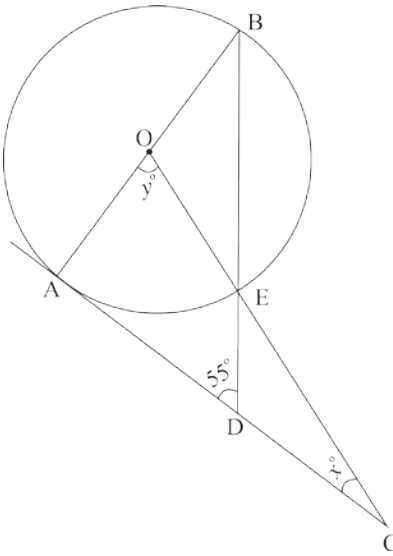

- (b) The model of a building is constructed with the scale factor 1 : 30. [3]
- (i) If the height of the model is 80 cm, find the actual height of the building in meters.
- (ii) If the actual volume of a tank at the top of the building is 27 m^3 , find the volume of the tank on the top of the model.
- (c) Given $\begin{bmatrix} 4 & 2 \\ -1 & 1 \end{bmatrix} M = 6I$, where M is a matrix and I is unit matrix of order 2×2 . [4]
- (i) State the order of matrix M.
- (ii) Find the matrix M.

Comments of Examiners

- (a) Some candidates were unable to identify $\angle BAD=90^\circ$ in the given figure. Hence, could not find $\angle ABD$, thereby got incorrect answers of x and y .

A number of candidates considered OADE as a cyclic quadrilateral and hence went wrong with the sum.

Many candidates solved the question without giving proper reasoning.

In some scripts simple calculation errors were also observed.

- (b) Many candidates were not clear about the *scale factor*. A number of candidates made calculation errors. A few candidates made mistakes in unit conversion i.e., cm to m and cm^3 to m^3 for example took $2400 \text{ cm} = 240 \text{ m}$ and $100 \text{ cm}^3 = 0.001 \text{ m}^3$.

A few of them left the answer in proper fraction as $1/1000$ without any unit and some left answer to subpart (ii) as 1000 without any unit.

- (c) (i) Some candidates were unable to find the order of the matrix.

Many were not aware that the matrix multiplication is not commutative and changed matrix M from right side in the given question to left side

$$\text{i.e., } \begin{bmatrix} 4 & 2 \\ -1 & 1 \end{bmatrix} M = 6I \text{ to } M \begin{bmatrix} 4 & 2 \\ -1 & 1 \end{bmatrix} = 6I$$

Some took the identity matrix as $\begin{bmatrix} 0 & 1 \\ 1 & 0 \end{bmatrix}$ instead

$$\text{of } \begin{bmatrix} 1 & 0 \\ 0 & 1 \end{bmatrix}$$

- (ii) Several candidates could not find the matrix multiplication correctly. Some candidates made mistake in framing the simultaneous equations and some could not find the values of the unknowns. A few got the values of the unknowns but did not arrange them in a matrix form.

Suggestions for teachers

- Exhaustive drill of properties of circle theorems and on application-based sums is must.
- Train students to give reasons supporting the answers while solving geometry-based questions.
- Teach students to name the angles with three letters, specifically when there are two or more angles at the same point, e.g., $\angle OED$ must not be named as $\angle E$ as it may mean $\angle CED$ or $\angle OEB$ or $\angle BEC$.
- Give sufficient practice of application-based problems on size transformation and proportionality.
- Intensive drill in conversion of units is must.
- Explain the concept of area, proportional to square of sides and concept of volume proportional to cube of sides.
- Instruct students to show each step of matrix multiplication.
- Ensure that enough practice is given in solving simultaneous equations.
- Train students to solve the sums involving identity matrix.

MARKING SCHEME

Question 7

(a)

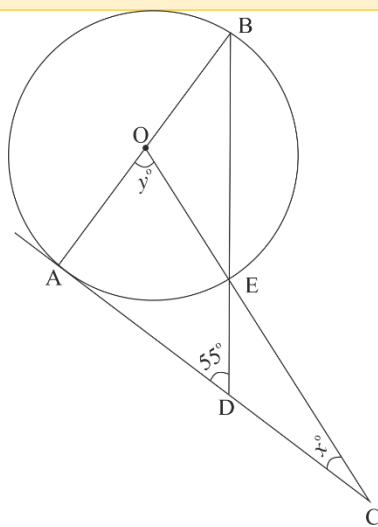

AC is a tangent and OA is the radius.

$$\therefore \angle BAC = 90^\circ$$

In $\triangle ABD$

$$\angle BAD = 90^\circ$$

$$\therefore \angle B = 180^\circ - (90^\circ + 55^\circ)$$

$$= 35^\circ$$

(angles of a triangle adds upto 180°)

$$\angle y = 2\angle B$$

$$\therefore y = 2 \times 35^\circ = 70^\circ \quad (\text{angle at the centre is double the angle in the remaining circumference})$$

In $\triangle AOC$

$$x = 180^\circ - (90^\circ + y)$$

$$= 180^\circ - (90^\circ + 70^\circ)$$

$$= 20^\circ$$

(angles of a triangle adds upto 180°)

(b)

$$K = \frac{1}{30}$$

Used correctly in height or volume

(i) Height of model = $\frac{1}{30} \times$ Actual height of the building

$$= 30 \times 80 \text{ cm} = \text{Actual height of the building}$$

$$\text{Actual height of the building} = 2400 \text{ cm} = 24 \text{ m}$$

OR

$$1 : 30 = 80 : x \text{ (where } x \text{ is the actual height of the building)}$$

$$\therefore x = 2400 \text{ cm} = 24 \text{ m.}$$

	<p>(ii) Volume of the tank on the top of the model</p> $= \left(\frac{1}{k}\right)^3 \times \text{Actual volume of tank at the top of the building}$ $= \frac{1 \times 27}{30 \times 30 \times 30} \text{ m}^3$ $= \frac{27 \times 100 \times 100 \times 100}{30 \times 30 \times 30} \text{ cm}^3$ $= 1000 \text{ cm}^3$
(c)	<p>(i) $(2 \times 2)(m \times n) = (2 \times 2) \rightarrow$ order of matrix, $M = (2 \times 2)$</p> <p>(ii) $\begin{bmatrix} 4 & 2 \\ -1 & 1 \end{bmatrix} \times \begin{bmatrix} a & b \\ c & d \end{bmatrix} = 6 \begin{bmatrix} 1 & 0 \\ 0 & 1 \end{bmatrix}$</p> $\begin{bmatrix} 4a + 2c & 4b + 2d \\ -a + c & -b + d \end{bmatrix} = \begin{bmatrix} 6 & 0 \\ 0 & 6 \end{bmatrix}$ $4a + 2c = 6$ $-a + c = 0$ $\therefore a = 1 \text{ and } c = 1$ $4b + 2d = 0$ $-b + d = 6$ $\therefore b = -2 \text{ and } d = 4$ $\therefore M = \begin{bmatrix} 1 & -2 \\ 1 & 4 \end{bmatrix}$

Question 8

- (a) The sum of the first three terms of an Arithmetic Progression (A.P.) is 42 and the product of the first and third term is 52. Find the first term and the common difference. [3]
- (b) The vertices of a ΔABC are $A(3, 8)$, $B(-1, 2)$ and $C(6, -6)$. Find: [3]
- (i) Slope of BC.
- (ii) Equation of a line perpendicular to BC and passing through A.
- (c) Using ruler and a compass only construct a semi-circle with diameter $BC = 7\text{cm}$. Locate a point A on the circumference of the semicircle such that A is equidistant from B and C. Complete the cyclic quadrilateral ABCD, such that D is equidistant from AB and BC. Measure $\angle ADC$ and write it down. [4]

Comments of Examiners

- (a) Many candidates took $a-d$, a and $a+d$ as three terms of Arithmetic Progression and found $a=14$ but while answering considered a as the first term instead of $a-d$. A number of candidates did not write $d=\pm 12$ but took $d=+12$ and hence found only one set of values. Some candidates could not form the correct equation with the given data.
- (b) Many candidates found the slope of the line BC correctly but failed to find the slope of a line perpendicular to BC. Some candidates found the midpoint of BC and used it to find the equation. Many candidates did not express the equation in the simplified form. In many scripts, calculation errors were also observed.
- (c) Concept of Locus was not clear to some candidates. Many candidates did not show the necessary traces of construction. Midpoint of BC was not located by construction instead used ruler. Some were unable to identify the point A as the intersection of perpendicular bisector and semi-circle. A number of candidates failed to bisect $\angle ABC$ to locate point D on the semicircle.

Suggestions for teachers

- Teach basic concepts of series in detail in the class.
- While taking square root of a number discuss the reason of taking values both with positive and negative signs unless otherwise specified in the question.
- Clarify the concept of slope of a line, equation of a line perpendicular or parallel to a given line in detail.
- Give rigorous practice on the content of coordinate geometry.
- Instruct students to be careful with positive and negative signs during simplification of equations.
- Give enough practice in problems based on geometry.
- Train students to practise constructions using ruler and compass only, unless otherwise specified in the question.
- Instruct students to show all necessary traces of construction clearly.

MARKING SCHEME

Question 8

- (a) Let the terms be $a-d, a, a+d$
 $\therefore a-d + a + a-d = 42$
 $3a = 42$
 $\therefore a = 14$
 $(a-d)(a+d) = 52$
 $14^2 - d^2 = 52$
 $d^2 = 196 - 52$
 $d^2 = 144$
 $\therefore d = \pm 12$
 $d = 12, \text{ or } -12$

(b) A(3, 8), B(-1, 2) and C(6, -6)

(i) Slope of line BC = $\frac{-6-2}{6+1} = \frac{-8}{7}$

(ii) Slope of line perpendicular to BC is $\frac{7}{8}$; Line passing through A(3, 8)

Equation is:

$$y - 8 = \frac{7}{8}(x - 3)$$

$$8y - 64 = 7x - 21$$

$$7x - 8y + 43 = 0$$

(c) $\angle ADC = 135^\circ$

Question 9

(a) The data on the number of patients attending a hospital in a month are given below. Find [3] the average (mean) number of patients attending the hospital in a month by using the shortcut method.

Take the assumed mean as 45. Give your answer correct to 2 decimal places.

Number of patients	10 – 20	20 – 30	30 – 40	40 – 50	50 – 60	60 – 70
Number of Days	5	2	7	9	2	5

- (b) Using properties of proportion solve for x , given [3]

$$\frac{\sqrt{5x} + \sqrt{2x - 6}}{\sqrt{5x} - \sqrt{2x - 6}} = 4$$

- (c) Sachin invests ₹8500 in 10%, ₹100 shares at ₹170. He sells the shares when the price of each share rises by ₹30. He invests the proceeds in 12% ₹100 shares at ₹125. Find: [4]
- the sale proceeds.
 - the number of ₹125 shares he buys.
 - the change in his annual income.

Comments of Examiners

- (a) Following errors were observed in this question:
- Class mark was incorrect.
 - Assumed mean was not taken as 45 as it was given in the question.
 - Some candidates did not use the short-cut method to find the mean.
 - A very common error was $121 \div 3$ was written as 4.33 instead of 40.33.
- (b) Many candidates made errors in applying Componendo and Dividendo especially in the denominator of Left-Hand Side. Some candidates applied properties of proportion only on one side. Several candidates made mistake in squaring the expression $\frac{2\sqrt{5x}}{2\sqrt{2x-6}} = \frac{5}{3}$
- (c) (i) Many candidates took sale price of the share as ₹130 instead of ₹200, Hence, answer to number of shares was incorrect. Calculation errors were also observed in many scripts.
- (ii) Many candidates could not find the correct answer for number of shares he bought due to error in calculating the sale proceeds.
- (iii) Error was also observed in the change in annual income due to incorrect value of number of shares.

Suggestions for teachers

- Advise students to read the question carefully and keep in mind the known and unknown data e.g., assumed mean =45, use short-cut method to find the mean, express your answer correct to 2 decimal places etc.
- Adequate practise of problems based on computation of mean must be given.
- Give more drill to avoid error in calculation.
- Revise frequently the problems on Ratio and Proportion.
- Show all steps of using properties of proportion in the solution of a problem clearly.
- Explain exhaustively the terms related to Share and Dividends-market value, face/nominal value, dividend etc thoroughly with examples.

MARKING SCHEME

Question 9

C.I	f	mid-value	d	fd
10 - 20	5	15	-30	-150
20 - 30	2	25	-20	-40
30 - 40	7	35	-10	-70
40 - 50	9	45	0	0
50 - 60	2	55	10	20
60 - 70	5	65	20	100
	30			-140

Given assumed mean (A) = 45

$$\text{Mean} = 45 + \left(\frac{-140}{30}\right)$$

$$= 45 - 4.67$$

$$= 40.33$$

(b) $\frac{\sqrt{5x} + \sqrt{2x-6}}{\sqrt{5x} - \sqrt{2x-6}} = 4$

$$\frac{\sqrt{5x} + \sqrt{2x-6} + \sqrt{5x} - \sqrt{2x-6}}{\sqrt{5x} + \sqrt{2x-6} - \sqrt{5x} + \sqrt{2x-6}} = \frac{4+1}{4-1}$$

Applying componendo and dividendo

$$\frac{2\sqrt{5x}}{2\sqrt{2x-6}} = \frac{5}{3}$$

Squaring both sides

$$\frac{5x}{2x-6} = \frac{25}{9}$$

$$45x = 50x - 150$$

$$5x = 150$$

$$\therefore x = 30$$

(c) Number of shares = $\frac{8500}{170} = 50$

Dividend = $\frac{50 \times 100 \times 10}{100} = ₹500$

(i) Sales proceeds = $50 \times (170+30) = ₹10,000$

(ii) New number of shares = $\frac{10,000}{125} = 80$

Dividend from new shares = $\frac{80 \times 100 \times 12}{100} = ₹960$

\therefore Change in income = $960 - 500 = ₹460$

Question 10

- (a) Use graph paper for this question.

[6]

The marks obtained by 120 students in an English test are given below:

Marks	0–10	10–20	20–30	30–40	40–50	50–60	60–70	70–80	80–90	90–100
No. of students	5	9	16	22	26	18	11	6	4	3

Draw the ogive and hence, estimate:

- (i) the median marks.
 - (ii) the number of students who did not pass the test if the pass percentage was 50.
 - (iii) the upper quartile marks.
- (b) A man observes the angle of elevation of the top of the tower to be 45° . He walks towards it in a horizontal line through its base. On covering 20 m the angle of elevation changes to 60° . Find the height of the tower correct to 2 significant figures. [4]

Comments of Examiners

- (a) (i) A number of candidates made mistakes in finding the cumulative frequency though the total frequency was given correctly. Some candidates drew the ogive with respect to lower boundaries and corresponding cumulative frequency instead of taking upper boundaries. Some candidates drew the ogive taking mid-values and corresponding cumulative frequency. To locate the various results from the graph indicating guidelines were not shown. Several candidates formed the S-curve by joining the points with ruler instead of free hand curve. In sub parts (ii) and (iii) some candidates made mistakes in finding median marks, upper quartile marks and number of students who did not pass the test.
- (b) The errors observed in this question were as follows:
- Many candidates drew incorrect diagram.
 - Some candidates wrote incorrect ratio for $\tan \theta$.

Suggestions for teachers

- Teach the students to cross-check the cumulative frequency found. This is by tallying the total frequency with the last value of C.F.
- Correct choice of axis and scale require additional attention.
- Ensure that sufficient practice is given in drawing Ogive.
- Instruct students to indicate on the graph sheet to locate values from the graph.
- Advise students to draw Ogive - a cumulative frequency curve as a free hand curve. Points must not be joined with a ruler.
- Give sufficient practice of drawing correct diagrams for problems based on Heights and Distances.

- Many calculation errors were observed in the scripts because of taking $\tan 60^\circ = 1.732$ instead of $\sqrt{3}$.

In several answer scripts height of tower was not expressed correct to 2 significant figures as it was asked in the question.

- Instruct students to learn the skill to find T-ratios of standard angles mathematical tables instead of using.
- Advise students read the question carefully to give the answer in the required form.
- Advise students to practice mathematical calculations each day to reduce calculation errors.

MARKING SCHEME

Question 10

(a)

C.I.	F	C.F.
0 – 10	5	5
10 – 20	9	14
20 – 30	16	30
30 – 40	22	52
40 – 50	26	78
50 – 60	18	96
60 – 70	11	107
70 – 80	6	113
80 – 90	4	117
90 – 100	3	120

SCALE: On X-axis, 1 cm = 20 marks

On Y-axis, 1 cm = 20 students

- (i) Median = 43 marks
- (ii) Number of students who did not pass the test 78
- (iii) 56 marks (± 1)

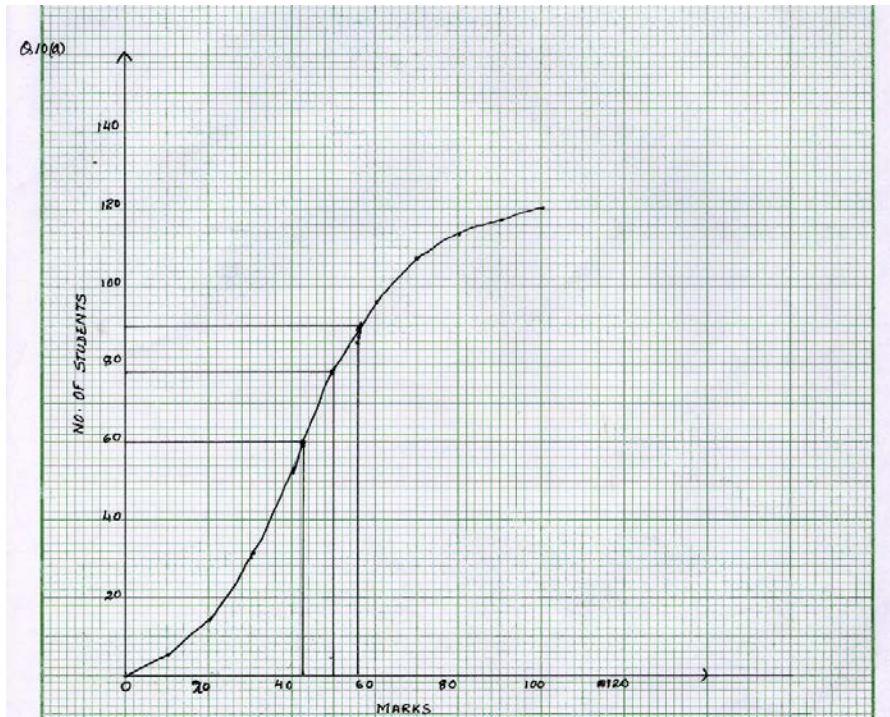

(b) $\tan 45^\circ = \frac{y}{x+20}$ { $\tan 45^\circ = 1$ }

$$1 = \frac{y}{x+20}$$

$$\therefore x + 20 = y$$

$$y - 20 = x$$

$$\tan 60^\circ = \frac{y}{x} \quad \{ \tan 60^\circ = \sqrt{3} \}$$

$$x \sqrt{3} = y$$

$$x = y/\sqrt{3}$$

$$y - 20 = y/\sqrt{3}$$

$$\therefore y = \frac{20(\sqrt{3})}{(\sqrt{3}-1)}, \quad y = \frac{20(\sqrt{3})(\sqrt{3}+1)}{(\sqrt{3}-1)(\sqrt{3}+1)}$$

$$x = \frac{20(1.732 + 3)}{3 - 1}$$

$$x = 10 \times 4.732$$

$$= 47.32 \text{ m}$$

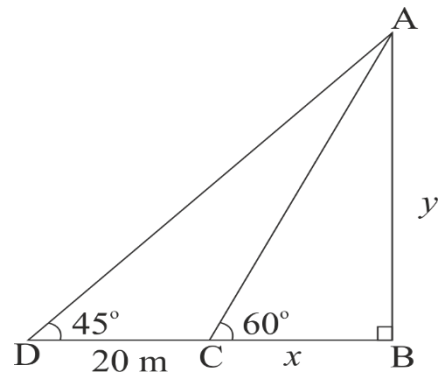

Question 11

- (a) Using the Remainder Theorem find the remainders obtained when [3]

$x^3 + (kx + 8)x + k$ is divided by $x + 1$ and $x - 2$.

Hence find k if the sum of the two remainders is 1.

- (b) The product of two consecutive natural numbers which are multiples of 3 is equal to 810. [3]

Find the two numbers.

- (c) In the given figure, ABCDE is a pentagon inscribed in a circle such that AC is a diameter [4]
and side $BC \parallel AE$. If $\angle BAC = 50^\circ$, find giving reasons:

- (i) $\angle ACB$
(ii) $\angle EDC$
(iii) $\angle BEC$

Hence prove that BE is also a diameter

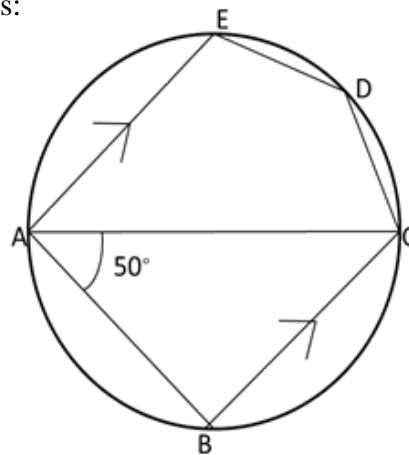

Comments of Examiners

- (a) Many candidates could not apply the Remainder theorem correctly.

Due to incorrect substitution or incorrect working some candidates found the incorrect remainder.

Several candidates instead of adding the two remainders, equated each remainder to zero that is $5k+24 = 0$ and $2k-9 = 0$.

- (b) The most common error noticed in several scripts was in taking two consecutive natural numbers which were multiples of 3.

Some candidates made mistakes in forming the equation with the given conditions.

Few candidates made errors in solving the quadratic equation.

- (c) (i) Following errors were observed in this question:

- Some candidates could not apply the appropriate property of circle theorem to find out the unknown angles.

Suggestions for teachers

- Instruct students to read the question heedfully and analyse the given conditions before solving the problem.
- Stress upon solving sums using given conditions only.
- Give adequate practice in solving
 - problems based on Remainder-Factor theorem and
 - word problems based on quadratic equation.
- Clarify to the students about the consecutive numbers with different conditions like multiples of 3 with examples.
- Give ample practice to solve quadratic equation.

- Some failed to locate angles in the same segment hence could not prove $\angle BEC = \angle BAC = 50^\circ$
- Properties of cyclic quadrilateral were not applied.
- Many candidates even after solving the other parts could not prove BE is a diameter giving proper reasons. Unable to find the values of $\angle ACB$, $\angle EDC$ and $\angle BEC$ giving appropriate reasons.

- Teach circles and related angle properties, cyclic properties, tangent and secant properties thoroughly.
- Train students to write correct reasons in support of the working of geometry based questions to obtain the answers.

MARKING SCHEME

Question 11

(a) $x^3 + (kx + 8)x + k = x^3 + kx^2 + 8x + k$

When divided by $x + 1$

$$\text{Remainder} = (-1)^3 + k(-1)^2 + 8(-1) + k$$

$$= -1 + k - 8 + k$$

$$= 2k - 9$$

When divided by $x - 2$

$$\text{Remainder} = (2)^3 + k(2)^2 + 8(2) + k$$

$$= 8 + 4k + 16 + k$$

$$= 5k + 24$$

$$\text{Hence } 2k - 9 + 5k + 24 = 1$$

$$7k + 15 = 1$$

$$7k = -14$$

$$\therefore k = -2$$

(b) *Assume that two consecutive natural numbers which are multiples of 3 are x and $x + 3$*

$$x(x + 3) = 810$$

$$x^2 + 3x = 810$$

$$x^2 + 3x - 810 = 0$$

$$(x + 30)(x - 27) = 0$$

$$x = -30 \text{ or } x = 27$$

therefore, the two numbers are 27 and 30.

(c) (i) In $\triangle ABC$, $\angle ABC = 90^\circ$ (Angle in a semi circle)
 $\angle BAC = 50^\circ$ (given)

$$\therefore \angle ACB = 40^\circ$$

(ii) $\therefore AE \parallel BC$

$$\therefore \angle CAE = \angle ACB = 40^\circ \quad (\text{pair of alternate } \angle\text{s})$$

In cyclic quadrilateral ACDE

$$\begin{aligned} \angle CAE + \angle EDC \\ = 180^\circ \quad (\text{opposite } \angle\text{s of cyclic quadrilateral are supplementary.}) \end{aligned}$$

$$40^\circ + \angle EDC = 180^\circ$$

$$\angle EDC = 140^\circ$$

(iii) $\angle BEC = \angle BAC = 50^\circ$ (angles in the same segment)

(iv) $\angle AEB = 90 - 50 = 40^\circ$

$$\therefore \angle EBC = 40^\circ \quad (\text{alternate angles})$$

$$\therefore \angle ECB = 90^\circ$$

$\therefore BE$ is a diameter.

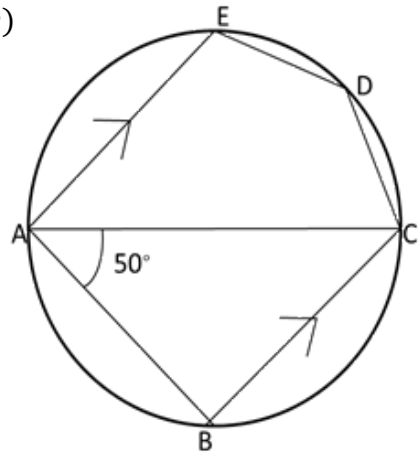

Note: For questions having more than one correct answer/solution, alternate correct answers/solutions, apart from those given in the marking scheme, have also been accepted.

GENERAL COMMENTS

Topics
found
difficult
/confusing by
candidates

- Linear inequation and representation
- Shares and Dividend
- Rationalization
- Algebraic division of polynomials by binomial and simplification.
- Rounding off answers to the desired form.
- Significant figures
- Arithmetic and Geometrical Progression
- Section formula and points on x and y axes
- Properties of Ratio and Proportion
- Geometry constructions
- Trigonometry
- Matrix- scalar multiplication and multiplication of 2 Matrices
- Graphs – Axes and choice of scale
- Size Transformation
- Mensuration formula
- Circle theorems
- Statistics- Calculation of Central tendency of non-grouped frequency distribution
- Calculation of Mean by Short-cut Method
- Remainder-Factor theorem
- Solving Geometry problems on circles and similar triangles using the appropriate property

Suggestions
for
candidates

- Prove trigonometrical identities by starting from left hand side and then proving it equal to right hand side or *vice a versa*.
- Write reasons while solving Geometry problems.
- Use mathematical tables to find square root, cube root of a number etc. to save time.
- Recheck the calculation to avoid calculation error.
- Be careful in conversion of units.
- Utilise reading time must be used judiciously to make the right choice of questions.
- Practise rounding off answers correct to required number of decimal places.
- Practise significant figures and express the answer up to asked digits in the question.
- Show clearly all steps of working including rough work on the same answer sheet.
- Show clearly all traces of construction while working with Geometrical Constructions.
- Practise thoroughly all formulae related to Coordinate geometry, mensuration etc.